

# 1HD4.40P Dry Vacuum



Industry-Leading Suction | 100% Oil & Water Free | Modular & Upgradable  
SKU: 2800005



Part #	2800005
Max (HV) Users	4
# Motors	1
Hp	2
Suction Power (Adjustable)	10-25" Hg
CFM Max	28
Amps	10.5 A
Volts (Min-Max)	230V, 1 Phase (207-253V)
Sound Level (dB)	69 dB
Vacuum LxWxH	28" x 18" x 19"
Vacuum Weight	130 lbs.
Tank LxWxH	16.5" x 16.5" x 31.5"
Tank Weight	40 lbs.
Min Vacuum Line Dia	1/2"
Recommended Line Dia	1 1/2"
Warranty	5 years / Unlimited Hours
Optional Buck-Boosts	1 (Purchased Separately)

## Product Highlights:



**100% Oil & Water Free**  
Save on water costs. No oil changes or oily exhaust residue.



**Industry Leading Suction Performance**  
Adjustable vacuum up to 25" Hg for surgical and multi-specialty applications.



**Works with 1" Dia or Smaller Pipes**  
Easily replace old wet vacuum systems without replacing in-floor plumbing.

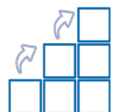

**Modular & Upgradable**  
Add new motor units and tank extensions to support up to 16 users.



**5-Year Warranty**  
Unlimited hour hassle-free warranty.

## Package Includes:

- One x 2Hp 100% Dry Vacuum Unit
- Improved 12-Gal Air/Water Separator Tank with Auto-Drain & Over-Flow Protection. **Includes Extra Float Sensor for Easy Upgrades – NEW!**
- NEMA-Rated Control Panel with Vacuum Gauge, Hour Meter and Start/Stop Control
- Remote Start Capability with Optional Remote Switch
- Exhaust Kit With Dual Drip-Leg Assembly
- Adjustable Bypass Vacuum Regulator with Industry-Leading Suction Range of 10-25 In Hg
- 10 Ft Vacuum Hose
- Phone, Email & Video Installation Support

### Optional Accessories:

Part #	Description
2900601	Buck/Boost Transformer
2900101	Low Voltage Remote Start/Stop
2900201	Vacuum Stand Small 24" x 30" 39"
2900204	Tank Elevation Stand 10"
2900205	Tank Elevation Stand 16"
2850003	NXT Hg5 Amalgam Separator

1.800.668.8736 - sales@basevacdental.com - www.basevacdental.com

# 1HD4.40P Dry Vacuum



Industry-Leading Suction | 100% Oil & Water Free | Modular & Upgradable  
 SKU: 2800005

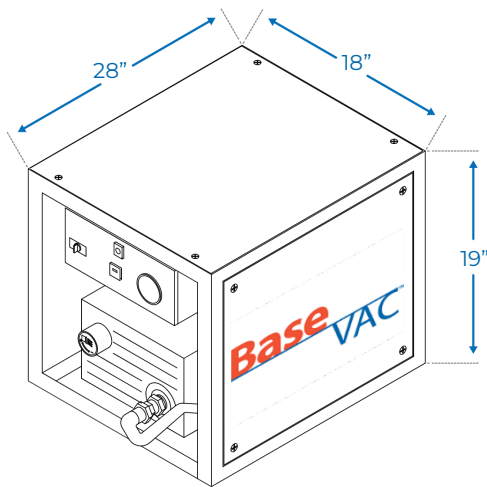
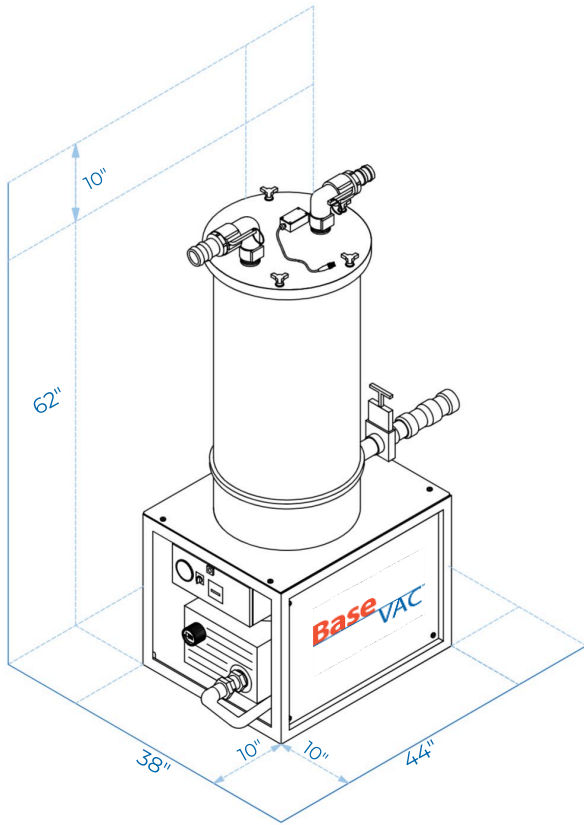

**Required Electrical Receptacle: L6-15P**

Site Requirements	
Voltage (Min/Max)	230V, 1 Phase (207-253V)
Breaker Rating	20 Amps
Wire Size	14 AWG
BTU/Hour	5000
Max Room Temperature	50 °F - 104 °F (10 °C – 40°C)
Install Footprint	44" x 38" x 56.75"
Shipping Specs	
Shipping Weight	208 lbs.
# of packages / pallets	3
Maintenance	
Primary Interval	Annual / 3,000 Hours
Includes	Vane & filter inspection. Replace if necessary. Requires 30-60 mins

### Note:

- System supplied with hose to connect dental to pump inlet and pump to air/water separator. 10 feet total.
- Exhaust piping can be metallic or plastic. It must be sloped away from supplied drip leg kit.
- The room must be provided with active ventilation.
- Allow 10" around and above the system for easy service access.
- A Buck/boost transformer is required for 208V Applications.

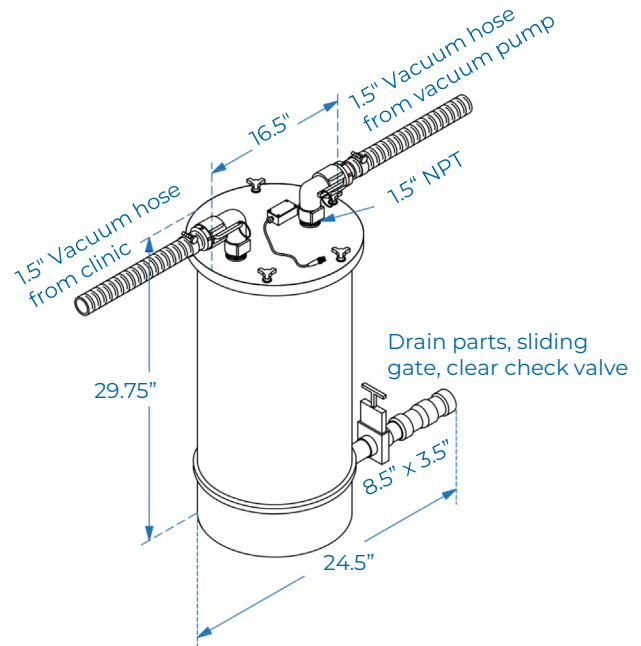

All models adjustable from 5" Hg to 25" Hg. Recommended set point 15" Hg to 20" Hg Max (HV). Users refers to the maximum number of users during normal working conditions (includes diversity). For 100% redundancy (back up/spare) do not count 2nd motor in calculation. Noise level measured at 3.5 feet with inlet and exhaust piping connected. Optional 3 Phase 230 / 460 / 575V Options Available.

1.800.668.8736 - sales@basevacdental.com - www.basevacdental.com